

APR 30/50

REVERSIBLE VIBRATORY PLATE

HONDA



HATZ

DESIGNED FOR HIGH PRODUCTIVITY

The APR 30/50 and APR 30/60 maintain the easy handling that is common to smaller reversible vibratory plates, but they add productivity potential with working widths of 50 cm (19.7 in) or 60 cm (23.6 in). That added capacity helps cover ground quickly, yet also maintains the “on-the-spot” capabilities, enabling a focus on particularly tough-to-compact areas.

PRODUCTIVITY

- **Superior compaction performance**
Powerful vibratory system generates high compaction forces for fast, comprehensive compaction.
- **Unmatched speed**
Balanced base plate enables superior mobility and high working speed.
- **Hydrostatic steering control**
Provides simple control and high accuracy even in confined areas.

ERGONOMICS

- **Low-vibration guide handle**
Industry-leading HAV values below 2.5 m/sec² protect operator and eliminate need for time-consuming record keeping.
- **Convenient guide handle**
Ergonomically optimised for ideal machine control during the working shift.
- **Secure transport**
Machine is easily secured during transport for convenience and safety.

SERVICEABILITY

- **Toolless daily inspection**
Quick and easy daily inspection.
- **Simplified maintenance work**
Service and regular maintenance points are quick and easily accessible.
- **Protective frame and covers**
Protects all key components against damage on the jobsite or during transport.

APPLICATIONS

- Earthwork and paving applications
- Road and rail track construction
- Compaction work in narrow trenches, confined areas
- Landscape and gardening
- Foundation work
- Sensitive surfaces (with optional rubber mats for stone protection)

TECHNICAL SPECIFICATIONS APR 30/50 REVERSIBLE VIBRATORY PLATE

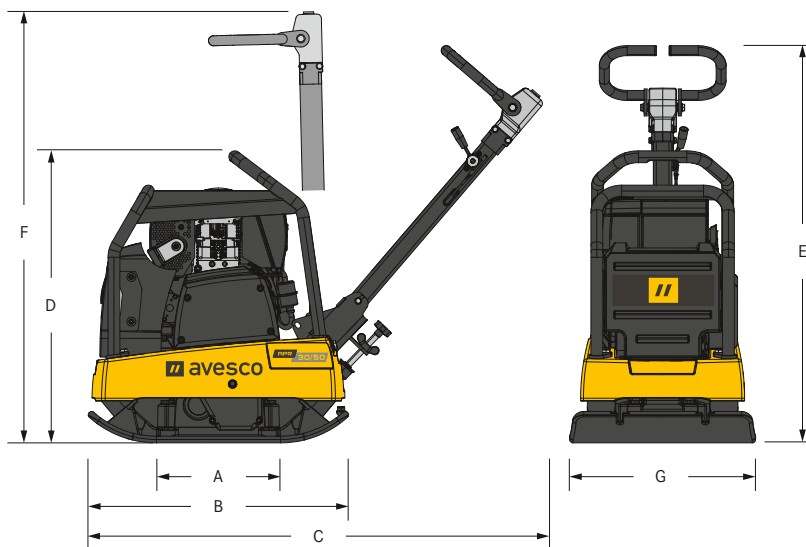

DIMENSIONS & WEIGHTS

	Honda	Hatz
MACHINE WEIGHT	199 kg	215 kg
MACHINE WEIGHT (WITH OPTIONS)	214 kg	242 kg
A BASE PLATE LENGTH	330 mm	330 mm
B MACHINE LENGTH	700 mm	700 mm
C WITH HANDLE	1140 mm	1140 mm
D MACHINE HEIGHT	765 mm	785 mm
E HANDLE HEIGHT (WORK)	1000 mm	1000 mm
F HANDLE HEIGHT (TRANSPORT)	1180 mm	1180 mm
G MACHINE WIDTH	500 mm	500 mm

COMPACTION FORCES

MAX. VIBRATION FREQUENCY	90 Hz	90 Hz
MAX. CENTRIFUGAL FORCE	32 kN	32 kN
WORKING SURFACE	780 m ² /h	870 m ² /h
SPEC. SURFACE PRESSURE	23,62 N/cm ²	23,62 N/cm ²

STANDARD EQUIPMENT

- Sturdy protection frame with central lifting point
- Vibration isolated handle bar
- Powerful and reliable petrol or diesel engine
- 2-shaft exciter with long service intervalls
- Well protected, sturdy centrifugal clutch with wear resistant V-Belt

ENGINE

	Honda	Hatz
ENGINE	Honda GX 270	Hatz 1 B 30
FUEL	Petrol	Diesel
ENGINE OUTPUT	6,3 kW (8,6 HP)	4,5 kW (6,1 HP)
AT RPM	3 100	2900
FUEL CONSUMPTION	2,1 l/h	2,1 l/h

MISCELLANEOUS

HAND-ARM VIBRATION ON HANDLE	<2,5 m/s ²	<2,5 m/s ²
SPEED	26 m/min	29 m/min
FUEL TANK	6,0 l	5,0 l
GRADEABILITY	35%	35%
MAX. INCLINE TO ALL SIDES	20°	30°
WATER TANK	-	-

OPTIONAL EQUIPMENT

- Transport wheels
- Hour meter