



M316

Wheeled Excavator

Technical Specifications

Configurations and features may vary by region. Please consult your Cat® dealer for availability in your area.

Table of Contents

Specifications	2
Engine	2
Transmission	2
Service Refill Capacities	2
Swing Mechanism	2
Undercarriage	2
Operating Weights	2
Major Component Weights	3
Hydraulic System	3
Tires	3
Dozer Blade	4
Emissions and Safety	4
Standards	4
Sound Performance	4
Air Conditioning System	4
Dimensions	5
Undercarriage Dimensions	6
Working Ranges	7
Lift Capacities:	
Variable Adjustable Boom (5205 mm), 2200 mm Stick	8
Variable Adjustable Boom (17'1"), 7'3" Stick	9
Variable Adjustable Boom (5205 mm), 2500 mm Stick	10
Variable Adjustable Boom (17'1"), 8'2" Stick	11
Bucket Specifications and Compatibility	12
Attachments Offering Guide	16
Standard and Optional Equipment	21
Dealer Installed Kits and Attachments	23
Cab Options	24
M316 Environmental Declaration	25

M316 Wheeled Excavator Specifications

Engine

Engine Model	Cat® 4.4	
Engine Power		
ISO 14396:2002	110 kW	148 hp
ISO 14396:2002 (metric)	150 hp (PS)	
Net Power		
ISO 9249:2007	104.9 kW	141 hp
ISO 9249:2007 (metric)	143 hp (PS)	
Bore	105 mm	4.1 in
Stroke	127 mm	5 in
Displacement	4.4 L	268.5 in ³
Biodiesel Capability	Up to B20 ⁽¹⁾	
Number of Cylinders	4	

- Meets U.S. EPA Tier 4 Final and EU Stage V emission standards.
- Net power advertised is the power available at the flywheel when engine is equipped with fan, air cleaner, CEM exhaust gas aftertreatment, alternator, and cooling fan running at intermediate speed.
- Recommended for use up to 3000 m (9,843 ft) altitude with engine power derate above 3000 m (9,843 ft).
- Rated speed 2,000 rpm.

⁽¹⁾Cat diesel engines are required to use ULSD (ultra-low sulfur diesel fuel with 15 ppm of sulfur or less) or ULSD blended with the following lower-carbon intensity fuels up to:

- ✓ 20% biodiesel FAME (fatty acid methyl ester)*
- ✓ 100% renewable diesel, HVO (hydrotreated vegetable oil) and GTL (gas-to-liquid) fuels

Refer to guidelines for successful application. Please consult your Cat dealer or “Caterpillar Machine Fluids Recommendations” (SEBU6250) for details.

**Engines with no aftertreatment devices can use higher blends, up to 100 % biodiesel (for use of blends higher than 20% biodiesel, consult your Cat dealer).*

Transmission

Forward/Reverse		
1st Gear	10 km/h	6.2 mph
2nd Gear	35 km/h	21.7 mph
Creeper Speed		
1st Gear	5.5 km/h	3.4 mph
2nd Gear	15 km/h	9.3 mph
Drawbar Pull	102 kN	22,931 lbf
Maximum Gradeability at (17 300 kg/38,140 lb)	73.0%	

Service Refill Capacities

Fuel Tank (total capacity)	350 L	92.5 gal
Diesel Exhaust Fluid Tank	20 L	5.3 gal
Cooling System	24 L	6.3 gal
Engine Oil	13 L	3.4 gal
Hydraulic Tank	120 L	31.7 gal
Hydraulic System (including tank)	260 L	68.7 gal
Rear Axle Housing (differential)	14 L	4 gal
Front Steering Axle (differential)	10.5 L	2.8 gal
Final Drive (each)	2.5 L	0.7 gal
Powershift Transmission	2.5 L	0.7 gal

Swing Mechanism

Maximum Swing Speed	10.2 rpm	
Maximum Swing Torque	43.8 kN·m	32,305 lb-ft

Undercarriage

Ground Clearance	365 mm	14.4 in
Maximum Steering Angle	35°	
Oscillation Axle Angle	± 8.5°	
Minimum Turning Radius		
Outside of Tire	6300 mm	20.7 ft
Outside of Tire (plastic fender)	7550 mm	24.8 ft
End of VA Boom	7300 mm	23.9 ft
Undercarriage steps for parallel blade		
Standard	2545 mm	8.3 ft
Wide	2720 mm	8.9 ft
Plastic type fenders for front and rear tires, for parallel blade		
Standard	2550 mm	8.4 ft
Wide	2720 mm	8.9 ft

Operating Weights*

Minimum	17 000 kg	37,480 lb
Maximum	18 400 kg	40,560 lb
Typical configurations		
Variable Adjustable Boom**		
Rear Blade Only	17 200 kg	37,920 lb
Blade and Outriggers	18 150 kg	40,010 lb
Front and Rear Outriggers	18 400 kg	40,560 lb

*Operating weight includes full fuel tank, operator, bucket 700 kg (1,543 lb) and dual pneumatic tires. Weight varies depending on configuration.

**Typical configurations include 2500 mm (8'2") stick, 3300 kg (7,280 lb) counterweight, bucket and 220 kg (485 lb) quick coupler.

M316 Wheeled Excavator Specifications

Major Component Weights

Booms (including VAB and stick cylinder, pins and standard hydraulic lines)		
Variable Adjustable Boom 5205 mm (17'1")	2200 kg	4,850 lb
Sticks (including cylinder, bucket linkage, pins and standard hydraulic lines)		
Stick 2200 mm (7'3")	790 kg	1,740 lb
Stick 2500 mm (8'2")	810 kg	1,790 lb
Counterweight		
3300 kg (7,280 lb)	3300 kg	7,280 lb
Undercarriage (including axles, standard tires and steps)		
Rear Blade	4450 kg	9,810 lb
Rear Blade/Front Outrigger	5400 kg	11,900 lb
Rear Outrigger/Front Blade	5400 kg	11,900 lb
Rear Outrigger/Front Outrigger	5650 kg	12,460 lb
Rear Blade Parallel	4960 kg	10,934 lb
Rear Blade Parallel with Trailer	5025 kg	11,078 lb
Front Blade/Rear Outrigger	5965 kg	13,151 lb
Front Blade/Rear Outrigger with Trailer:	6030 kg	13,294 lb
Buckets		
Pin-On Bucket GD 1200 mm (47"), 0.80 m ³ (1.05 yd ³)	680 kg	1,500 lb
Pin-On Bucket GD 1200 mm (47"), 0.91 m ³ (1.19 yd ³)	700 kg	1,540 lb
CW Bucket GD 1200 mm (47"), 0.91 m ³ (1.19 yd ³)	680 kg	1,500 lb
Quick Couplers		
CW30 Dedicated Quick Coupler	220 kg	490 lb
Pin Grabber Quick Coupler	300 kg	660 lb

Hydraulic System

Maximum Pressure – Implement Circuit		
Normal	35 000 kPa	5,076 psi
Heavy Lift	37 000 kPa	5,366 psi
Travel Circuit	35 000 kPa	5,076 psi
Maximum Pressure – Auxiliary Circuit		
High Pressure	35 000 kPa	5,076 psi
Medium Pressure	17 000 kPa	2,466 psi
Swing Mechanism	35 000 kPa	5,076 psi
Maximum Flow		
Implements	275 L/min	73 gal/min
Travel Circuit	190 L/min	50 gal/min
Auxiliary Circuit		
High Pressure	250 L/min	66 gal/min
Medium Pressure	55 L/min	14.5 gal/min
Swing Mechanism	106 L/min	28.0 gal/min
Cylinders		
Boom Cylinder – Bore	115 mm	5"
Boom Cylinder – Stroke	916 mm	3'0"
VAB Cylinder – Bore	140 mm	6"
VAB Cylinder – Stroke	743 mm	2'5"
Stick Cylinder – Bore	115 mm	5"
Stick Cylinder – Stroke	1147 mm	3'9"
Bucket Cylinder – Bore	100 mm	4"
Bucket Cylinder – Stroke	1055 mm	3'6"

Tires

Standard	10.00-20 (dual pneumatic)
Optional	11.00-20 (dual pneumatic) 315/70R22.5 (dual pneumatic without spacer) 445/70/R19.5 TL XF (single pneumatic)

M316 Wheeled Excavator Specifications

Dozer Blade

Blade Type	Radial	
Width	2540 mm	8'4"
Blade Roll-Over Height	540 mm	1'9"
Blade Total Height	580 mm	1'11"
Maximum Lowering Depth From Ground	120 mm	5"
Maximum Raising Height Above Ground	475 mm	1'7"

Emissions and Safety

Engine Emissions	Tier 4 Final and Stage V	
Vibration Levels		
Maximum Hand/Arm (ISO 5349-2001)	<2.5 m/s ²	<8.2
Maximum Whole Body (ISO/TR 25398:2006)	<0.5 m/s ²	<1.6
Seat Transmissibility Factor (ISO 7096:2000-spectral class EM5)	<0.7	

Standards

Brakes	ISO 10265:2008
Cab/Rollover Protective Structure (ROPS)	ISO 12117-2:2008
Falling Object Guard System (FOGS) (optional)	ISO 10262:1998 Level II
Cab/Sound Levels	Meets appropriate standards as listed below

Sound Performance

Operator Sound	
2000/14/EC	70 dB(A)
Spectator Sound	
2000/14/EC	102 dB(A)

- Operator Sound – The operator sound level is measured according to the procedures specified in 2000/14/EC, for a cab offered by Caterpillar, when properly installed and maintained and tested with the door and windows closed.
- Exterior Sound – The labeled spectator sound power level is measured according to the test procedures and conditions specified in 2000/14/EC.
- Hearing protection may be needed when operating with an open operator station and cab (when not properly maintained for doors/windows open) for extended periods or in noisy environment(s).

Air Conditioning System

The air conditioning system on this machine contains the fluorinated greenhouse gas refrigerant R134a (Global Warming Potential = 1430). The system contains 0.85 kg of refrigerant, which has a CO₂ equivalent of 1.216 metric tonnes.

M316 Wheeled Excavator Specifications

Dimensions

All dimensions are approximate. Values are with 10.00-20 dual pneumatic tires.

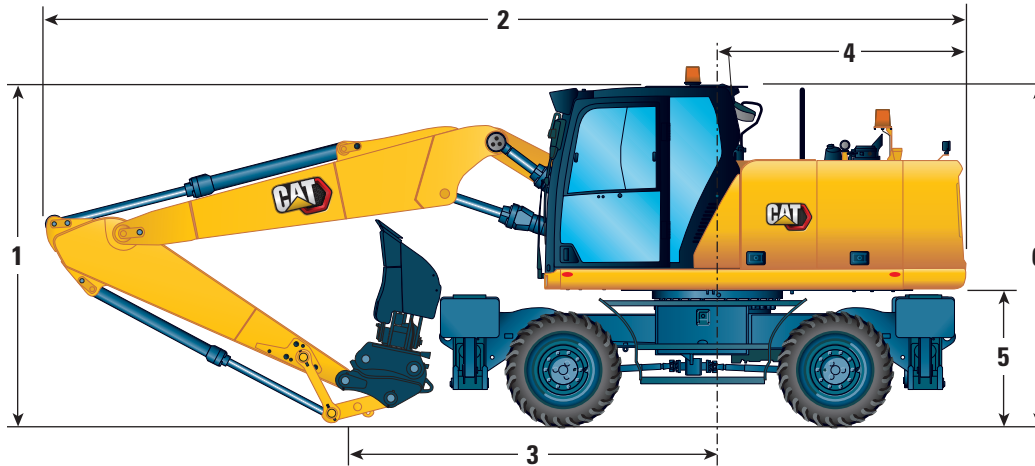

Boom Option

Variable Adjustable Boom 5205 mm (17'1")

Stick Options

2200 mm
(7'3")

2500 mm
(8'2")

1 Shipping Height with Falling Object Guard (highest point between boom and cab)	3360 mm (11'0")	3360 mm (11'0")
Shipping Height without FOGS	3180 mm (10'5")	3210 mm (10'6")
2 Shipping Length	8640 mm (28'4")	8710 mm (28'7")
3 Support Point	3870 mm (12'8")	3530 mm (11'7")
4 Tail Swing Radius	2350 mm (7'9")	2350 mm (7'9")
5 Counterweight Clearance	1301 mm (4'3")	1301 mm (4'3")
6 Cab Height		
No Falling Object Guard	3194 mm (10'6")	3194 mm (10'6")
With Falling Object Guard	3356 mm (11'0")	3356 mm (11'0")
Overall Machine Width		
Width with Outriggers on Ground	3800 mm (12'6")	3800 mm (12'6")
Width with Outriggers Up	2540 mm (8'4")	2540 mm (8'4")
Width with Blade	2540 mm (8'4")	2540 mm (8'4")
7 Width with Outriggers Fully Down	3645 mm (12'0")	3645 mm (12'0")
Enclosure Height (doors)	2500 mm (8'2")	2500 mm (8'2")
8 Upperframe Width	2540 mm (8'4")	2540 mm (8'4")
Roading Position		
9 Steering Wheel to Linkage in Roading Position	2880 mm (9'5")	2870 mm (9'5")
10 Height in Roading Position	3930 mm (12'11")	3950 mm (13'0")

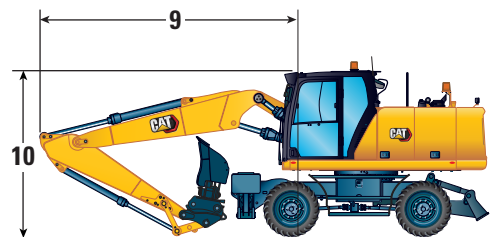

M316 Wheeled Excavator Specifications

Undercarriage Dimensions

All dimensions are approximate. Values are with 10.00-20 dual pneumatic tires.

Undercarriage	Rear Blade	Rear Blade/ Front Outrigger	Rear Outrigger/ Front Blade	Rear Outrigger/ Front Outrigger
11 Overall Undercarriage Length	4360 mm (14'4")	4970 mm (16'4")	4970 mm (16'4")	4805 mm (15'9")
12 Wheel Base	2550 mm (8'4")	2550 mm (8'4")	2550 mm (8'4")	2550 mm (8'4")
13 Swing Bearing Center to Rear Axle Center	1100 mm (3'7")	1100 mm (3'7")	1100 mm (3'7")	1100 mm (3'7")
14 Swing Bearing Center to Front Axle Center	1450 mm (4'9")	1450 mm (4'9")	1450 mm (4'9")	1450 mm (4'9")
15 Rear Axle to Rear Outrigger (mid)	—	—	830 mm (2'9")	830 mm (2'9")
16 Front Axle to Front Outrigger (mid)	—	925 mm (3'0")	—	925 mm (3'0")
17 Rear Axle to Blade (end)	1270 mm (4'2")	1270 mm (4'2")	—	—
Front Axle to Blade (end)	—	—	1315 mm (4'4")	—
18 Maximum Outrigger Depth	—	115 mm (5")	115 mm (5")	115 mm (5")
19 Blade Width	2540 mm (8'4")	2540 mm (8'4")	2540 mm (8'4")	—
Maximum Blade Depth Below Ground	120 mm (5")	120 mm (5")	120 mm (5")	—
Ground Clearance				
Lowest Step Clearance	395 mm (1'4")	395 mm (1'4")	395 mm (1'4")	395 mm (1'4")
20 Outrigger Clearance	335 mm (1'1")	335 mm (1'1")	335 mm (1'1")	335 mm (1'1")
21 Blade Clearance	475 mm (8'4")	475 mm (8'4")	475 mm (8'4")	475 mm (8'4")
22 Axle Clearance	365 mm (1'2")	365 mm (1'2")	365 mm (1'2")	365 mm (1'2")

*Maximum tire clearance with outrigger fully down



Undercarriage with dozer only

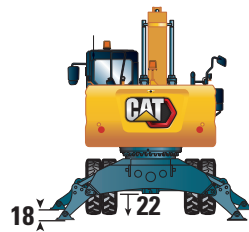
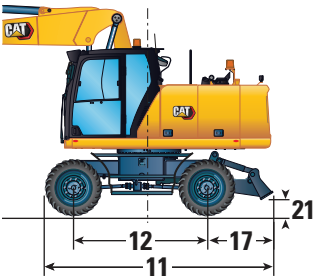

Undercarriage with 2 sets of outriggers

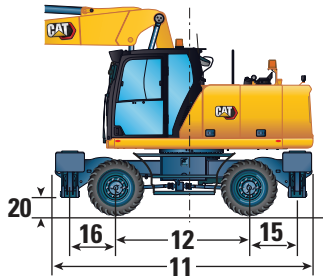

Undercarriage with 1 set of outriggers and dozer

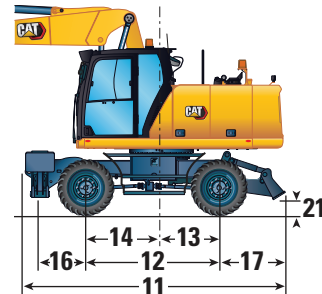

M316 Wheeled Excavator Specifications

Working Ranges

All Dimensions are approximate. Values are with 10.00-20 Dual Pneumatic Tires.

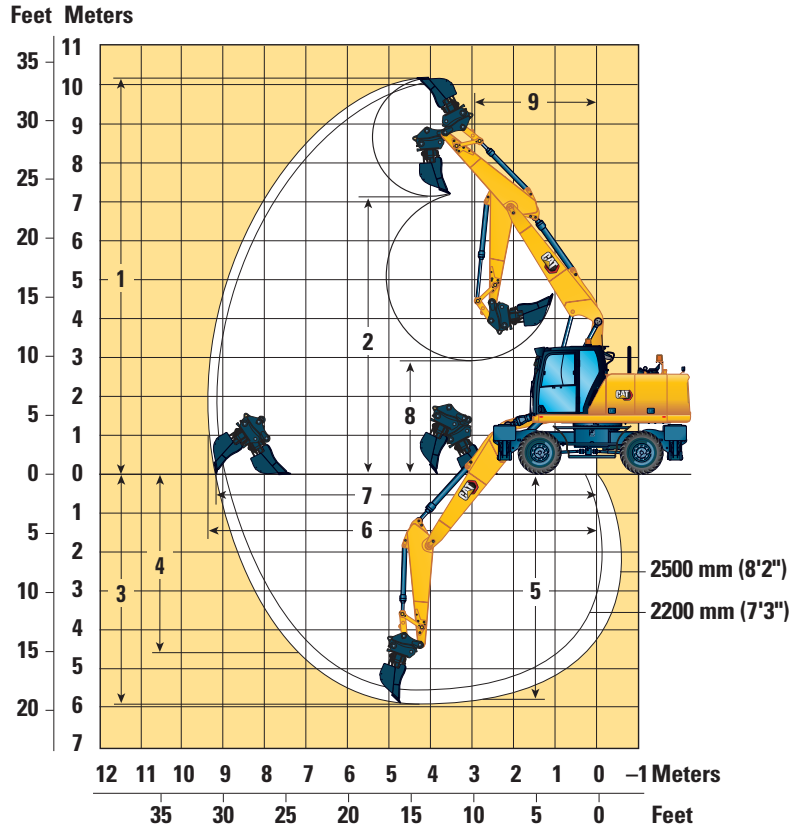

Boom Option	Variable Adjustable Boom	
	2200 mm (7'3")	2500 mm (8'2")
Stick Options		
1 Maximum Cutting Height	10 110 mm (33'2")	10 240 mm (33'7")
2 Maximum Loading Height	7140 mm (23'5")	7280 mm (23'11")
3 Maximum Digging Depth	5630 mm (18'6")	5920 mm (19'5")
4 Maximum Vertical Wall Digging Depth	4410 mm (14'6")	4620 mm (15'2")
5 Maximum Depth Cut for 2440 mm (8'0") Level Bottom	5520 mm (18'1")	5810 mm (19'1")
6 Maximum Reach	9140 mm (30'0")	9390 mm (30'10")
7 Maximum Reach at Ground Line	8970 mm (29'5")	9220 mm (30'3")
8 Minimum Loading Height	3290 mm (10'10")	2940 mm (9'8")
9 Minimum Front Swing Radius	2950 mm (9'8")	2900 mm (9'6")
Bucket Forces (ISO)	119 kN (26,752 lbf)	119 kN (26,752 lbf)
Stick Forces (ISO)	75 kN (16,861 lbf)	69 kN (15,512 lbf)
Bucket Type	GD	GD
Bucket Capacity	0.8 m ³ (1.05 yd ³)	0.8 m ³ (1.05 yd ³)
Bucket Tip Radius (Pin-On)	1378 mm (4'6")	1378 mm (4'6")
Bucket Tip Radius (QC)	1484 mm (4'10")	1484 mm (4'10")

Range values are with dual pneumatic tires (10.00-20).

Range values are calculated with a GD bucket (CW) and CW-30 quick coupler with a tip radius of 1484 mm (4'10").

Force values are calculated with heavy lift on, a GD bucket (pin-on) and a tip radius of 1378 mm (4'6").

M316 Wheeled Excavator Specifications

Lift Capacities – Variable Adjustable Boom (5205 mm), 2200 mm Stick

All values are in kg, work tool: none, bucket cylinder and bucket linkage installed, counterweight: 3300 kg, heavy lift function on.

		Load at maximum reach (sticknose/bucket pin)			Load over front			Load over rear			Load over side			Load point height					
	Undercarriage configuration	3000 mm			4500 mm			6000 mm			7500 mm						mm		
7500 mm	Front empty – rear radial dozer – raised				*4950	4750	4250										*3800	*3800	3650
	Front empty – rear radial dozer – lowered				*4950	*4950	4800										*3800	*3800	*3800
	Front radial dozer – rear stab – lowered				*4950	*4950	*4950										*3800	*3800	*3800
	Front stab – rear stab – lowered				*4950	*4950	*4950										*3800	*3800	*3800
6000 mm	Front empty – rear radial dozer – raised				*4950	4800	4300	4300	2950	2650							*3150	2650	2350
	Front empty – rear radial dozer – lowered				*4950	*4950	4800	4300	*4450	2950							*3150	*3150	2650
	Front radial dozer – rear stab – lowered				*4950	*4950	*4950	*4450	*4450	*4450							*3150	*3150	*3150
	Front stab – rear stab – lowered				*4950	*4950	*4950	*4450	*4450	*4450							*3150	*3150	*3150
4500 mm	Front empty – rear radial dozer – raised				*5950	4550	4050	4250	2900	2600							*2900	2100	1900
	Front empty – rear radial dozer – lowered				*5950	*5950	4550	4200	*5000	2900							*2900	*2900	2150
	Front radial dozer – rear stab – lowered				*5950	*5950	*5950	*5000	*5000	4400							*2900	*2900	*2900
	Front stab – rear stab – lowered				*5950	*5950	*5950	*5000	*5000	*5000							*2900	*2900	*2900
3000 mm	Front empty – rear radial dozer – raised				6350	4150	3700	4050	2750	2450	2850	1900	1700				2800	1850	1650
	Front empty – rear radial dozer – lowered				6300	*7150	4200	4050	*5300	2750	2850	*3400	1900				2800	*2800	1900
	Front radial dozer – rear stab – lowered				*7150	*7150	6600	*5300	*5300	4250	*3400	*3400	3000				*2800	*2800	*2800
	Front stab – rear stab – lowered				*7150	*7150	*7150	*5300	*5300	5100	*3400	*3400	*3400				*2800	*2800	*2800
1500 mm	Front empty – rear radial dozer – raised				5950	3850	3350	3900	2550	2300	2800	1850	1650				2700	1800	1600
	Front empty – rear radial dozer – lowered				5950	*7750	3850	3900	*5650	2600	2800	4200	1850				*2900	*2900	2150
	Front radial dozer – rear stab – lowered				*7750	*7750	6200	*5650	*5650	4050	*4350	4300	2950				*2900	*2900	2850
	Front stab – rear stab – lowered				*7750	*7750	7650	*5650	*5650	4900	*4350	*4350	3500				*2900	*2900	*2900
0 mm	Front empty – rear radial dozer – raised				5800	3650	3200	3800	2450	2200							2800	1850	1600
	Front empty – rear radial dozer – lowered				5750	*7600	3700	3800	*5550	2500							2800	*3150	1850
	Front radial dozer – rear stab – lowered				*7600	*7600	6050	*5550	*5550	3950							*3150	*3150	2900
	Front stab – rear stab – lowered				*7600	*7600	7450	*5550	*5550	4800							*3150	*3150	*3150
-1500 mm	Front empty – rear radial dozer – raised	*6050	*6050	5900	5750	3650	3200	3750	2450	2150							3150	2050	1800
	Front empty – rear radial dozer – lowered	*6050	*6050	*6050	5750	*6650	3650	3750	*4850	2450							3100	*3650	2050
	Front radial dozer – rear stab – lowered	*6050	*6050	*6050	*6650	*6650	6000	*4850	*4850	3950							*3650	*3650	3250
	Front stab – rear stab – lowered	*6050	*6050	*6050	*6650	*6650	*6650	*4850	*4850	4750							*3650	*3650	*3650
-3000 mm	Front empty – rear radial dozer – raised				*4800	3750	3300												
	Front empty – rear radial dozer – lowered				*4800	*4800	3750												
	Front radial dozer – rear stab – lowered				*4800	*4800	*4800												
	Front stab – rear stab – lowered				*4800	*4800	*4800												

*Indicates that the load is limited by hydraulic lifting capacity rather than tipping load.

Oscillating axle needs to be locked. Weight of all lifting accessories must be subtracted from the lifting capacities. All lift capacities calculated and rated per ISO 10567:2007. Rated loads do not exceed 87% of hydraulic lift capacity or 75% of tipping load. Heavy Lift Function ON. Lifting capacities are based on the machine standing on a firm uniform supporting surface. The load point is the center line of the bucket pivot mounting pin on the stick. Lift capacity is calculated with VA cylinder completely extracted. The use of a work tool attachment point to handle/lift objects, could affect the machine lift performance.

Always refer to the appropriate Operation and Maintenance Manual for specific product information.

M316 Wheeled Excavator Specifications

Lift Capacities – Variable Adjustable Boom (17'1"), 7'3" Stick

All values are in lb, work tool: none, bucket cylinder and bucket linkage installed, counterweight: 7,280 lb, heavy lift function on.

		Load at maximum reach (sticknose/bucket pin)			Load over front			Load over rear			Load over side			Load point height					
	Undercarriage configuration	10 ft			15 ft			20 ft			25 ft								
																	ft		
25 ft	Front empty – rear radial dozer – raised				*10,100	*10,100	9,100										*8,600	*8,600	8,500
	Front empty – rear radial dozer – lowered				*10,100	*10,100	*10,100										*8,600	*8,600	*8,600
	Front radial dozer – rear stab – lowered				*10,100	*10,100	*10,100										*8,600	*8,600	*8,600
	Front stab – rear stab – lowered				*10,100	*10,100	*10,100										*8,600	*8,600	*8,600
20 ft	Front empty – rear radial dozer – raised				*10,900	10,300	9,300	*8,800	6,300	5,600							*6,900	6,000	5,300
	Front empty – rear radial dozer – lowered				*10,900	*10,900	10,300	*8,800	*8,800	6,300							*6,900	*6,900	6,000
	Front radial dozer – rear stab – lowered				*10,900	*10,900	*10,900	*8,800	*8,800	*8,800							*6,900	*6,900	*6,900
	Front stab – rear stab – lowered				*10,900	*10,900	*10,900	*8,800	*8,800	*8,800							*6,900	*6,900	*6,900
15 ft	Front empty – rear radial dozer – raised				*12,800	9,800	8,800	9,100	6,200	5,600							*6,400	4,700	4,200
	Front empty – rear radial dozer – lowered				*12,800	*12,800	9,900	9,100	*10,800	6,200							*6,400	*6,400	4,700
	Front radial dozer – rear stab – lowered				*12,800	*12,800	*12,800	*10,800	*10,800	9,500							*6,400	*6,400	*6,400
	Front stab – rear stab – lowered				*12,800	*12,800	*12,800	*10,800	*10,800	*10,900							*6,400	*6,400	*6,400
10 ft	Front empty – rear radial dozer – raised				13,700	9,000	8,000	8,800	5,900	5,200							*6,200	4,100	3,700
	Front empty – rear radial dozer – lowered				13,600	*15,400	9,000	8,700	*11,400	5,900							6,200	*6,200	4,200
	Front radial dozer – rear stab – lowered				*15,400	*15,400	14,200	*11,400	*11,400	9,100							*6,200	*6,200	*6,200
	Front stab – rear stab – lowered				*15,400	*15,400	*15,400	*11,400	*11,400	11,000							*6,200	*6,200	*6,200
5 ft	Front empty – rear radial dozer – raised				12,800	8,300	7,300	8,400	5,500	4,900	6,000	4,000	3,500				6,000	3,900	3,500
	Front empty – rear radial dozer – lowered				12,800	*16,800	8,300	8,400	*12,200	5,600	6,000	*7,400	4,000				6,000	*6,400	4,000
	Front radial dozer – rear stab – lowered				*16,800	*16,800	13,400	*12,200	*12,200	8,800	*7,400	*7,400	6,300				*6,400	*6,400	6,300
	Front stab – rear stab – lowered				*16,800	*16,800	16,500	*12,200	*12,200	10,600	*7,400	*7,400	*7,400				*6,400	*6,400	*6,400
0 ft	Front empty – rear radial dozer – raised				12,400	7,900	6,900	8,200	5,300	4,700							6,200	4,000	3,600
	Front empty – rear radial dozer – lowered				12,400	*16,500	7,900	8,100	*12,000	5,400							6,200	*6,900	4,100
	Front radial dozer – rear stab – lowered				*16,500	*16,500	13,000	*12,000	*12,000	8,500							*6,900	*6,900	6,400
	Front stab – rear stab – lowered				*16,500	*16,500	16,000	*12,000	*12,000	10,300							*6,900	*6,900	*6,900
-5 ft	Front empty – rear radial dozer – raised	*13,900	*13,900	12,700	12,400	7,900	6,900	8,100	5,300	4,700							6,900	4,500	4,000
	Front empty – rear radial dozer – lowered	*13,900	*13,900	*13,900	12,300	*14,400	7,900	8,100	*10,500	5,300							6,900	*8,000	4,600
	Front radial dozer – rear stab – lowered	*13,900	*13,900	*13,900	*14,400	*14,400	12,900	*10,500	*10,500	8,500							*8,000	*8,000	7,200
	Front stab – rear stab – lowered	*13,900	*13,900	*13,900	*14,400	*14,400	*14,400	*10,500	*10,500	10,300							*8,000	*8,000	*8,000
-10 ft	Front empty – rear radial dozer – raised				*10,200	8,100	7,100												
	Front empty – rear radial dozer – lowered				*10,200	*10,200	8,100												
	Front radial dozer – rear stab – lowered				*10,200	*10,200	*10,200												
	Front stab – rear stab – lowered				*10,200	*10,200	*10,200												

*Indicates that the load is limited by hydraulic lifting capacity rather than tipping load.

Oscillating axle needs to be locked. Weight of all lifting accessories must be subtracted from the lifting capacities. All lift capacities calculated and rated per ISO 10567:2007. Rated loads do not exceed 87% of hydraulic lift capacity or 75% of tipping load. Heavy Lift Function ON. Lifting capacities are based on the machine standing on a firm uniform supporting surface. The load point is the center line of the bucket pivot mounting pin on the stick. Lift capacity is calculated with VA cylinder completely extracted. The use of a work tool attachment point to handle/lift objects, could affect the machine lift performance.

Always refer to the appropriate Operation and Maintenance Manual for specific product information.

M316 Wheeled Excavator Specifications

Lift Capacities – Variable Adjustable Boom (5205 mm), 2500 mm Stick

All values are in kg, work tool: none, bucket cylinder and bucket linkage installed, counterweight: 3300 kg, heavy lift function on.

		Load at maximum reach (sticknose/bucket pin)			Load over front			Load over rear			Load over side			Load point height						
	Undercarriage configuration	3000 mm			4500 mm			6000 mm			7500 mm						mm			
7500 mm	Front empty – rear radial dozer – raised				*4350	*4350	*4350										*3050	*3050	*3050	5280
	Front empty – rear radial dozer – lowered				*4350	*4350	*4350										*3050	*3050	*3050	
	Front radial dozer – rear stab – lowered				*4350	*4350	*4350										*3050	*3050	*3050	
	Front stab – rear stab – lowered				*4350	*4350	*4350										*3050	*3050	*3050	
6000 mm	Front empty – rear radial dozer – raised				*4300	*4300	*4300	*4050	3000	2700							*2600	2500	2200	6610
	Front empty – rear radial dozer – lowered				*4300	*4300	*4300	*4050	*4050	3000							*2600	*2600	2500	
	Front radial dozer – rear stab – lowered				*4300	*4300	*4300	*4050	*4050	*4050							*2600	*2600	*2600	
	Front stab – rear stab – lowered				*4300	*4300	*4300	*4050	*4050	*4050							*2600	*2600	*2600	
4500 mm	Front empty – rear radial dozer – raised				*5150	4650	4150	4300	2900	2600							*2450	2000	1800	7400
	Front empty – rear radial dozer – lowered				*5150	*5150	4650	4250	*4850	2950							*2450	*2450	2000	
	Front radial dozer – rear stab – lowered				*5150	*5150	*5150	*4850	*4850	4450							*2450	*2450	*2450	
	Front stab – rear stab – lowered				*5150	*5150	*5150	*4850	*4850	*4850							*2450	*2450	*2450	
3000 mm	Front empty – rear radial dozer – raised				6400	4250	3750	4100	2750	2450	2900	1900	1700				*2450	1800	1600	7810
	Front empty – rear radial dozer – lowered				6400	*6900	4250	4100	*5150	2750	2900	*3900	1950				*2450	*2450	1800	
	Front radial dozer – rear stab – lowered				*6900	*6900	6700	*5150	*5150	4250	*3900	*3900	3000				*2450	*2450	*2450	
	Front stab – rear stab – lowered				*6900	*6900	*6900	*5150	*5150	5150	*3900	*3900	3600				*2450	*2450	*2450	
1500 mm	Front empty – rear radial dozer – raised				6000	3900	3400	3950	2600	2300	2800	1850	1650				*2550	1700	1500	7900
	Front empty – rear radial dozer – lowered				6000	*7700	3900	3900	*5600	2600	2800	4200	1850				*2550	*2550	1700	
	Front radial dozer – rear stab – lowered				*7700	*7700	6250	*5600	*5600	4100	*4350	4300	2950				*2550	*2550	*2550	
	Front stab – rear stab – lowered				*7700	*7700	*7700	*5600	*5600	4950	*4350	*4350	3550				*2550	*2550	*2550	
0 mm	Front empty – rear radial dozer – raised				5800	3700	3200	3800	2450	2200	2750	1800	1600				2650	1750	1550	7700
	Front empty – rear radial dozer – lowered				5800	*7700	3700	3800	*5600	2500	2750	4150	1800				2650	*2800	1750	
	Front radial dozer – rear stab – lowered				*7700	*7700	6050	*5600	*5600	3950	*4150	*4150	2900				*2800	*2800	2800	
	Front stab – rear stab – lowered				*7700	*7700	7500	*5600	*5600	4800	*4150	*4150	3450				*2800	*2800	*2800	
-1500 mm	Front empty – rear radial dozer – raised	*6300	*6300	5850	5750	3650	3200	3750	2450	2150							2950	1950	1700	7170
	Front empty – rear radial dozer – lowered	*6300	*6300	*6300	5750	*6900	3650	3750	*5050	2450							2950	*3250	1950	
	Front radial dozer – rear stab – lowered	*6300	*6300	*6300	*6900	*6900	6000	*5050	*5050	3900							*3250	*3250	3050	
	Front stab – rear stab – lowered	*6300	*6300	*6300	*6900	*6900	*6900	*5050	*5050	4750							*3250	*3250	*3250	
-3000 mm	Front empty – rear radial dozer – raised				*5250	3700	3250	*3500	2500	2200										
	Front empty – rear radial dozer – lowered				*5250	*5250	3700	*3500	*3500	2500										
	Front radial dozer – rear stab – lowered				*5250	*5250	*5250	*3500	*3500	*3500										
	Front stab – rear stab – lowered				*5250	*5250	*5250	*3500	*3500	*3500										

*Indicates that the load is limited by hydraulic lifting capacity rather than tipping load.

Oscillating axle needs to be locked. Weight of all lifting accessories must be subtracted from the lifting capacities. All lift capacities calculated and rated per ISO 10567:2007. Rated loads do not exceed 87% of hydraulic lift capacity or 75% of tipping load. Heavy Lift Function ON. Lifting capacities are based on the machine standing on a firm uniform supporting surface. The load point is the center line of the bucket pivot mounting pin on the stick. Lift capacity is calculated with VA cylinder completely extracted. The use of a work tool attachment point to handle/lift objects, could affect the machine lift performance.

Always refer to the appropriate Operation and Maintenance Manual for specific product information.

M316 Wheeled Excavator Specifications

Lift Capacities – Variable Adjustable Boom (17'1"), 8'2" Stick

All values are in lb, work tool: none, bucket cylinder and bucket linkage installed, counterweight: 7,280 lb, heavy lift function on.

		Load at maximum reach (sticknose/bucket pin)			Load over front			Load over rear			Load over side			Load point height					
	Undercarriage configuration	10 ft			15 ft			20 ft			25 ft								
																	ft		
25 ft	Front empty – rear radial dozer – raised				*9,400	*9,400	9,300										*6,800	*6,800	*6,800
	Front empty – rear radial dozer – lowered				*9,400	*9,400	*9,400										*6,800	*6,800	*6,800
	Front radial dozer – rear stab – lowered				*9,400	*9,400	*9,400										*6,800	*6,800	*6,800
	Front stab – rear stab – lowered				*9,400	*9,400	*9,400										*6,800	*6,800	*6,800
20 ft	Front empty – rear radial dozer – raised				*9,500	*9,500	9,400	*8,600	6,400	5,800							*5,800	5,600	5,000
	Front empty – rear radial dozer – lowered				*9,500	*9,500	*9,500	*8,600	*8,600	6,400							*5,800	*5,800	5,600
	Front radial dozer – rear stab – lowered				*9,500	*9,500	*9,500	*8,600	*8,600	*8,600							*5,800	*5,800	*5,800
	Front stab – rear stab – lowered				*9,500	*9,500	*9,500	*8,600	*8,600	*8,600							*5,800	*5,800	*5,800
15 ft	Front empty – rear radial dozer – raised				*11,200	10,000	8,900	9,200	6,300	5,600							*5,400	4,500	4,000
	Front empty – rear radial dozer – lowered				*11,200	*11,200	10,000	9,200	*10,500	6,300							*5,400	*5,400	4,500
	Front radial dozer – rear stab – lowered				*11,200	*11,200	*11,200	*10,500	*10,500	9,600							*5,400	*5,400	*5,400
	Front stab – rear stab – lowered				*11,200	*11,200	*11,200	*10,500	*10,500	*10,500							*5,400	*5,400	*5,400
10 ft	Front empty – rear radial dozer – raised				13,800	9,200	8,100	8,800	5,900	5,300	6,200	4,100	3,700				*5,400	3,900	3,500
	Front empty – rear radial dozer – lowered				13,800	*14,900	9,200	8,800	*11,200	6,000	6,200	*7,600	4,100				*5,400	*5,400	4,000
	Front radial dozer – rear stab – lowered				*14,900	*14,900	14,400	*11,200	*11,200	9,200	*7,600	*7,600	6,500				*5,400	*5,400	*5,400
	Front stab – rear stab – lowered				*14,900	*14,900	*14,900	*11,200	*11,200	11,000	*7,600	*7,600	*7,600				*5,400	*5,400	*5,400
5 ft	Front empty – rear radial dozer – raised				13,000	8,400	7,400	8,500	5,600	5,000	6,100	4,000	3,500				*5,600	3,800	3,300
	Front empty – rear radial dozer – lowered				12,900	*16,600	8,400	8,400	*12,100	5,600	6,000	9,000	4,000				*5,600	*5,600	3,800
	Front radial dozer – rear stab – lowered				*16,600	*16,600	13,500	*12,100	*12,100	8,800	*9,300	9,300	6,300				*5,600	*5,600	*5,600
	Front stab – rear stab – lowered				*16,600	*16,600	16,600	*12,100	*12,100	10,600	*9,300	*9,300	7,600				*5,600	*5,600	*5,600
0 ft	Front empty – rear radial dozer – raised				12,500	7,900	7,000	8,200	5,300	4,700	6,000	3,900	3,400				5,900	3,800	3,400
	Front empty – rear radial dozer – lowered				12,400	*16,700	8,000	8,200	*12,100	5,400	5,900	*7,800	3,900				5,900	*6,100	3,900
	Front radial dozer – rear stab – lowered				*16,700	*16,700	13,000	*12,100	*12,100	8,500	*7,800	*7,800	6,200				*6,100	*6,100	6,100
	Front stab – rear stab – lowered				*16,700	*16,700	16,100	*12,100	*12,100	10,300	*7,800	*7,800	7,500				*6,100	*6,100	*6,100
-5 ft	Front empty – rear radial dozer – raised	*14,400	*14,400	12,600	12,400	7,800	6,900	8,100	5,200	4,600							6,500	4,300	3,800
	Front empty – rear radial dozer – lowered	*14,400	*14,400	*14,400	12,300	*15,000	7,900	8,100	*10,900	5,300							6,500	*7,200	4,300
	Front radial dozer – rear stab – lowered	*14,400	*14,400	*14,400	*15,000	*15,000	12,900	*10,900	*10,900	8,400							*7,200	*7,200	6,800
	Front stab – rear stab – lowered	*14,400	*14,400	*14,400	*15,000	*15,000	*15,000	*10,900	*10,900	10,300							*7,200	*7,200	*7,200
-10 ft	Front empty – rear radial dozer – raised				*11,300	8,000	7,000	7,200*	5,400	4,800									
	Front empty – rear radial dozer – lowered				*11,300	*11,300	8,000	*7,200	*7,200	5,500									
	Front radial dozer – rear stab – lowered				*11,300	*11,300	*11,300	*7,200	*7,200	*7,200									
	Front stab – rear stab – lowered				*11,300	*11,300	*11,300	*7,200	*7,200	*7,200									

*Indicates that the load is limited by hydraulic lifting capacity rather than tipping load.

Oscillating axle needs to be locked. Weight of all lifting accessories must be subtracted from the lifting capacities. All lift capacities calculated and rated per ISO 10567:2007. Rated loads do not exceed 87% of hydraulic lift capacity or 75% of tipping load. Heavy Lift Function ON. Lifting capacities are based on the machine standing on a firm uniform supporting surface. The load point is the center line of the bucket pivot mounting pin on the stick. Lift capacity is calculated with VA cylinder completely extracted. The use of a work tool attachment point to handle/lift objects, could affect the machine lift performance.

Always refer to the appropriate Operation and Maintenance Manual for specific product information.

M316 Wheeled Excavator Specifications

Bucket Specifications and Compatibility

Contact your Cat dealer for special bucket requirements.

	Linkage	Width		Capacity		Weight		Fill %	3300 kg (7,280 lb) Counterweight									
		Variable Angle Boom								2200 mm (7'3") Stick				2500 mm (8'2") Stick				
		Free on wheels	Only dozer (blade) lowered	Dozer (blade) and two stabilizers (outrigger) lowered	Four stabilizers (outrigger) lowered	Free on wheels	Only dozer (blade) lowered		Dozer (blade) and two stabilizers (outrigger) lowered	Four stabilizers (outrigger) lowered	Free on wheels	Only dozer (blade) lowered	Dozer (blade) and two stabilizers (outrigger) lowered	Four stabilizers (outrigger) lowered	Free on wheels	Only dozer (blade) lowered	Dozer (blade) and two stabilizers (outrigger) lowered	Four stabilizers (outrigger) lowered
Pin-On (No Quick Coupler)																		
General Duty	316	600	24	0.35	0.46	440	969	100	●	●	●	●	●	●	●	●	●	
	316	900	36	0.62	0.81	546	1,203	100	⊖	●	●	●	⊖	⊖	●	●	●	
	316	1200	48	0.91	1.19	658	1,450	100	◇	○	●	●	◇	◇	●	●	●	
	316	1300	51	1.00	1.31	695	1,532	100	X	◇	●	●	X	◇	●	●	●	
Ditch Cleaning	316	2000	78	0.94	1.23	723	1,594	100	◇	◇	●	●	X	◇	●	●	●	
Ditch Cleaning Tilt	316	2000	79	0.86	1.12	1028	2,266	100	X	◇	●	●	X	X	●	●	●	
Maximum load with pin-on (payload + bucket)									kg	1540	1790	2973	3631	1456	1694	2825	3452	
									lb	3,396	3,945	6,555	8,005	3,209	3,735	6,228	7,609	
With Pin Grabber Coupler																		
General Duty	316	600	24	0.35	0.46	440	969	100	●	●	●	●	⊖	●	●	●	●	
	316	900	36	0.62	0.81	546	1,203	100	◇	⊖	●	●	◇	○	●	●	●	
	316	1200	48	0.91	1.19	658	1,450	100	X	◇	●	●	X	X	●	●	●	
	316	1300	51	1.00	1.31	695	1,532	100	X	X	⊖	●	X	X	⊖	●	●	
Ditch Cleaning	316	2000	78	0.94	1.23	723	1,594	100	X	X	●	●	X	X	⊖	●	●	
Ditch Cleaning Tilt	316	2000	79	0.86	1.12	1028	2,266	100	X	X	⊖	●	X	X	⊖	●	●	
Maximum load with coupler (payload + bucket)									kg	1209	1459	2642	3300	1125	1363	2494	3121	
									lb	2,666	3,216	5,825	7,276	2,480	3,006	5,499	6,880	

Maximum Material Density:

- 2100 kg/m³ (3,500 lb/yd³)
- ⊖ 1800 kg/m³ (3,000 lb/yd³)
- ⊖ 1500 kg/m³ (2,500 lb/yd³)
- 1200 kg/m³ (2,000 lb/yd³)
- ◇ 900 kg/m³ (1,500 lb/yd³)
- X Not Recommended

The above loads are in compliance with hydraulic excavator standard EN474-5:2006+A3:2013, they do not exceed 87% of hydraulic lifting capacity or 75% of tipping capacity with front linkage fully extended at ground line with bucket curled. Capacity based on ISO 7451.

Caterpillar recommends using appropriate work tools to maximize the value customers receive from our products. Use of work tools, including buckets, which are outside of Caterpillar's recommendations or specifications for weight, dimensions, flows, pressures, etc. may result in less-than-optimal performance, including but not limited to reductions in production, stability, reliability, and component durability. Improper use of a work tool resulting in sweeping, prying, twisting and/or catching of heavy loads will reduce the life of the boom and stick.

(continued on next page)

M316 Wheeled Excavator Specifications

Bucket Specifications and Compatibility (continued)

Contact your Cat dealer for special bucket requirements.

Linkage	mm	in	Capacity		Weight		Fill	3300 kg (7,280 lb) Counterweight									
								Variable Angle Boom									
								2200 mm (7'3") Stick				2500 mm (8'2") Stick					
								Free on wheels	Only dozer (blade) lowered	Dozer (blade) and two stabilizers (outrigger) lowered	Four stabilizers (outrigger) lowered	Free on wheels	Only dozer (blade) lowered	Dozer (blade) and two stabilizers (outrigger) lowered	Four stabilizers (outrigger) lowered		
With CW-30 Coupler																	
General Duty	316	600	24	0.35	0.46	439	967	100	●	●	●	●	●	●	●	●	●
	316	750	30	0.49	0.64	475	1,047	100	⊙	●	●	●	⊖	●	●	●	●
	316	900	36	0.62	0.81	534	1,177	100	○	⊖	●	●	○	⊖	●	●	●
	316	1100	43	0.80	1.04	593	1,307	100	◇	○	●	●	X	◇	●	●	●
	316	1200	48	0.90	1.18	646	1,423	100	X	◇	●	●	X	◇	●	●	●
	316	1300	51	1.00	1.31	677	1,492	100	X	◇	●	●	X	X	⊙	●	●
Heavy Duty	316	1300	51	1.00	1.31	694	1,529	100	X	◇	●	●	X	X	⊙	●	●
General Duty – Leveling Edge	316	996	39.2	0.70	0.93	586	1,291	100	◇	○	●	●	◇	○	●	●	●
	316	1200	47	0.91	1.19	672	1,481	100	X	◇	●	●	X	◇	●	●	●
	316	690	27	0.47	0.61	476	1,049	100	⊙	●	●	●	⊖	●	●	●	●
	316	790	31	0.56	0.73	509	1,122	100	⊖	⊙	●	●	○	⊙	●	●	●
Ditch Cleaning Tilt	316	1800	72	0.78	1.02	1048	2,310	100	X	X	●	●	X	X	●	●	●
	316	2000	79	0.86	1.13	1111	2,449	100	X	X	⊙	●	X	X	⊙	●	●
Maximum load with coupler (payload + bucket)								kg	1328	1578	2761	3419	1244	1482	2613	3240	
								lb	2,928	3,478	6,087	7,538	2,742	3,268	5,761	7,142	
With CW-30S Coupler																	
General Duty	316	600	24	0.35	0.46	423	932	100	●	●	●	●	●	●	●	●	●
	316	750	30	0.49	0.64	471	1,038	100	⊙	●	●	●	⊖	●	●	●	●
	316	900	36	0.62	0.81	534	1,177	100	○	⊖	●	●	⊖	⊖	●	●	●
	316	1100	43	0.80	1.04	593	1,307	100	◇	○	●	●	X	◇	●	●	●
	316	1200	48	0.91	1.18	646	1,423	100	X	◇	●	●	X	◇	●	●	●
	316	1300	51	1.00	1.31	677	1,492	100	X	◇	●	●	X	X	⊙	●	●
Heavy Duty	316	1200	48	0.91	1.18	663	1,461	100	X	◇	●	●	X	◇	●	●	●
Ditch Cleaning Tilt	316	1300	51	1.00	1.31	695	1,531	100	X	◇	●	●	X	X	⊙	●	●
	316	2000	79	0.86	1.13	1092	2,407	100	X	X	⊙	●	X	X	⊙	●	●
Maximum load with coupler (payload + bucket)								kg	1336	1586	2769	3427	1252	1490	2621	3248	
								lb	2,946	3,495	6,105	7,556	2,760	3,286	5,779	7,160	

Maximum Material Density:

- 2100 kg/m³ (3,500 lb/yd³)
- ⊙ 1800 kg/m³ (3,000 lb/yd³)
- ⊖ 1500 kg/m³ (2,500 lb/yd³)
- 1200 kg/m³ (2,000 lb/yd³)
- ◇ 900 kg/m³ (1,500 lb/yd³)

The above loads are in compliance with hydraulic excavator standard EN474-5:2006+A3:2013, they do not exceed 87% of hydraulic lifting capacity or 75% of tipping capacity with front linkage fully extended at ground line with bucket curled. Capacity based on ISO 7451.

Caterpillar recommends using appropriate work tools to maximize the value customers receive from our products. Use of work tools, including buckets, which are outside of Caterpillar's recommendations or specifications for weight, dimensions, flows, pressures, etc. may result in less-than-optimal performance, including but not limited to reductions in production, stability, reliability, and component durability. Improper use of a work tool resulting in sweeping, prying, twisting and/or catching of heavy loads will reduce the life of the boom and stick.

(continued on next page)

M316 Wheeled Excavator Specifications

Bucket Specifications and Compatibility (continued)

Contact your Cat dealer for special bucket requirements.

	Linkage	Width		Capacity		Weight		Fill	3300 kg (7,280 lb) Counterweight									
										Variable Angle Boom								
										2200 mm (7'3") Stick				2500 mm (8'2") Stick				
		mm	in	m ³	yd ³	kg	lb		%	Free on wheels	Only dozer (blade) lowered	Dozer (blade) and two stabilizers (outrigger) lowered	Four stabilizers (outrigger) lowered	Free on wheels	Only dozer (blade) lowered	Dozer (blade) and two stabilizers (outrigger) lowered	Four stabilizers (outrigger) lowered	
With S60 Coupler																		
Heavy Duty	0	1100	43	0.80	1.05	628	1,385	100	◇	○	●	●	X	◇	●	●		
	0	1150	45	0.90	1.18	699	1,641	100	X	◇	●	●	X	◇	●	●		
								kg	1364	1614	2797	3455	1280	1518	2649	3276		
								lb	3,008	3,557	6,167	7,617	2,821	3,347	5,840	7,221		
No Machine Coupler, TRS14 CW30																		
Grading – General Duty	316	1700	67	0.65	0.85	634	1,397	100	X	X	●	●	X	X	●	●		
Trenching – General Duty	316	660	26	0.45	0.59	395	871	100	◇	⊖	●	●	X	○	●	●		
								kg	818	1068	2251	2909	734	972	2103	2730		
								lb	1,804	2,353	4,963	6,414	1,618	2,144	4,637	6,018		
No Machine Coupler, TRS14 CW30S																		
Grading – General Duty	316	1600	63	0.75	0.98	595	1,311	100	X	X	●	●	X	X	●	●		
								kg	864	1114	2297	2955	780	1018	2149	2776		
								lb	1,905	2,455	5,064	6,515	1,719	2,245	4,738	6,119		
No Machine Coupler, TRS14 S60																		
Grading – General Duty	316	1500	59	0.52	0.68	511	1,127	100	◇	○	●	●	X	○	●	●		
	316	1500	59	0.65	0.85	535	1,179	100	X	◇	●	●	X	◇	●	●		
	316	1600	63	0.75	0.98	576	1,270	100	X	X	●	●	X	X	●	●		
Trenching – General Duty	316	540	21	0.33	0.43	320	706	100	⊙	●	●	●	⊖	●	●	●		
								kg	965	1215	2398	3056	881	1119	2250	2877		
								lb	2,128	2,678	5,287	6,738	1,942	2,468	4,961	6,342		

Maximum Material Density:

- 2100 kg/m³ (3,500 lb/yd³)
- ⊙ 1800 kg/m³ (3,000 lb/yd³)
- ⊖ 1500 kg/m³ (2,500 lb/yd³)
- 1200 kg/m³ (2,000 lb/yd³)
- ◇ 900 kg/m³ (1,500 lb/yd³)
- X Not Recommended

The above loads are in compliance with hydraulic excavator standard EN474-5:2006+A3:2013, they do not exceed 87% of hydraulic lifting capacity or 75% of tipping capacity with front linkage fully extended at ground line with bucket curled. Capacity based on ISO 7451.

Caterpillar recommends using appropriate work tools to maximize the value customers receive from our products. Use of work tools, including buckets, which are outside of Caterpillar's recommendations or specifications for weight, dimensions, flows, pressures, etc. may result in less-than-optimal performance, including but not limited to reductions in production, stability, reliability, and component durability. Improper use of a work tool resulting in sweeping, prying, twisting and/or catching of heavy loads will reduce the life of the boom and stick.

(continued on next page)

M316 Wheeled Excavator Specifications

Bucket Specifications and Compatibility (continued)

Contact your Cat dealer for special bucket requirements.

	Linkage	3300 kg (7,280 lb) Counterweight								Variable Angle Boom															
		Width				Capacity				Weight				Fill				2200 mm (7'3") Stick				2500 mm (8'2") Stick			
		mm		in		m³		yd³		kg		lb		%		Free on wheels	Only dozer (blade) lowered	Dozer (blade) and two stabilizers (outrigger) lowered	Four stabilizers (outrigger) lowered	Free on wheels	Only dozer (blade) lowered	Dozer (blade) and two stabilizers (outrigger) lowered	Four stabilizers (outrigger) lowered		
		mm	in	m³	yd³	kg	lb	%	Free on wheels	Only dozer (blade) lowered	Dozer (blade) and two stabilizers (outrigger) lowered	Four stabilizers (outrigger) lowered	Free on wheels	Only dozer (blade) lowered	Dozer (blade) and two stabilizers (outrigger) lowered	Four stabilizers (outrigger) lowered									
CW30, TRS14 CW30																									
Grading – General Duty	316	1700	67	0.65	0.85	634	1,397	100	X	X	●	●	X	X	⊙	●									
Trenching – General Duty	316	660	26	0.45	0.59	395	871	100	X	◇	●	●	X	X	●	●									
								Maximum load with coupler (payload + bucket)		kg	592	842	2025	2683	508	746	1877	2504							
										lb	1,306	1,855	4,465	5,915	1,119	1,645	4,138	5,519							
CW30S, TRS14 CW30S																									
Grading – General Duty	316	1600	63	0.75	0.98	595	1,311	100	X	X	●	●	X	X	●	●									
								Maximum load with pin-on (payload + bucket)		kg	667	917	2100	2758	583	821	1952	2579							
										lb	1,471	2,021	4,630	6,081	1,285	1,811	4,304	5,685							
S60, TRS14 S60																									
Grading – General Duty	316	1600	63	0.75	0.98	576	1,270	100	X	X	●	●	X	X	●	●									
	316	1700	67	0.80	1.05	610	1,346	100	X	X	●	●	X	X	⊙	●									
	316	1800	71	0.90	1.18	643	1,418	100	X	X	⊙	●	X	X	⊖	●									
Trenching – General Duty	316	540	21	0.33	0.43	540	1,190	100	◇	⊖	●	●	X	○	●	●									
								Maximum load with coupler (payload + bucket)		kg	824	1074	2257	2915	740	978	2109	2736							
										lb	1,817	2,367	4,976	6,427	1,631	2,157	4,650	6,031							

Maximum Material Density:

- 2100 kg/m³ (3,500 lb/yd³)
- ⊙ 1800 kg/m³ (3,000 lb/yd³)
- ⊖ 1500 kg/m³ (2,500 lb/yd³)
- 1200 kg/m³ (2,000 lb/yd³)
- ◇ 900 kg/m³ (1,500 lb/yd³)
- X Not Recommended

The above loads are in compliance with hydraulic excavator standard EN474-5:2006+A3:2013, they do not exceed 87% of hydraulic lifting capacity or 75% of tipping capacity with front linkage fully extended at ground line with bucket curled. Capacity based on ISO 7451.

Caterpillar recommends using appropriate work tools to maximize the value customers receive from our products. Use of work tools, including buckets, which are outside of Caterpillar's recommendations or specifications for weight, dimensions, flows, pressures, etc. may result in less-than-optimal performance, including but not limited to reductions in production, stability, reliability, and component durability. Improper use of a work tool resulting in sweeping, prying, twisting and/or catching of heavy loads will reduce the life of the boom and stick.

M316 Wheeled Excavator Specifications

Attachments Offering Guide

Not all attachments are available in all regions. Consult your Cat dealer for configurations available in your region.

Match
 No Match
 Working range front only
 1800 kg/m³ (3,000 lb/yd³)
 1200 kg/m³ (2,000 lb/yd³)
 600 kg/m³ (1,000 lb/yd³)

PIN-ON ATTACHMENTS

Undercarriage		Rear Outrigger/ Front Blade		Rear Blade/ Front Outrigger		Rear Outrigger/ Front Outrigger		Rear Blade	
		3300 kg (7,280 lb)		3300 kg (7,280 lb)		3300 kg (7,280 lb)		3300 kg (7,280 lb)	
Boom Type		Variable Adjustable Boom		Variable Adjustable Boom		Variable Adjustable Boom		Variable Adjustable Boom	
		2200 mm (7'3")	2500 mm (8'2")	2200 mm (7'3")	2500 mm (8'2")	2200 mm (7'3")	2500 mm (8'2")	2200 mm (7'3")	2500 mm (8'2")
Stick Length		2200 mm (7'3")	2500 mm (8'2")	2200 mm (7'3")	2500 mm (8'2")	2200 mm (7'3")	2500 mm (8'2")	2200 mm (7'3")	2500 mm (8'2")
Hydraulic Hammers	H110 S	✓	✓	✓	✓	✓	✓	✓	✓
	H115 GC S	✓	✓	✓	✓	✓	✓	✓	✓
	H115 S	✓	✓	✓	✓	✓	✓	✓	✓
Demolition and Sorting Grapples	G313 GC	✓	✓	✓	✓	✓	✓	✓	✓
	G314	✓	✓	✓	✓	✓	✓	✓	✓*
	G317 GC	✓	✓	✓	✓	✓	✓		
Mobile Scrap and Demolition Shears	S3015 Flat Top	✓	✓	✓	✓	✓	✓	✓	✓*
Compactors (Vibratory Plate)	CVP75	✓	✓	✓	✓	✓	✓	✓	✓
Orange Peel Grapples	GSH420-500	●	●	●	●	●	●	○	
	GSH420-600	●	●	●	●	●	●		
	GSH420-750	●	○	●	○	●	○		
	GSH520-500	●	●	●	●	●	●		
	GSH520-600	●	○	●	○	●	○		
	GSH520-750	○	○	○	○	○	○		
	GSV520 GC-400	●	●	●	●	●	●	○	○
	GSV520 GC-500	●	●	●	●	●	●	○	
	GSV520 GC-600	●	●	●	●	●	●		
	GSV520 GC-750	●	○	●	○	●	○		
	GSV420-400	●	●	●	●	●	●	●	○
	GSV420-500	●	●	●	●	●	●	○	○
	GSV420-600	●	●	●	●	●	●		
	GSV420-750	●	○	●	○	●	○		
	GSV420-1250	◇	◇	◇	◇	◇	◇		
	GSV520-400	●	●	●	●	●	●	○	○
	GSV520-500	●	●	●	●	●	●		
	GSV520-600	●	○	●	○	●	○		
	GSV520-750	●	○	●	○	●	○		

(continued on next page)

M316 Wheeled Excavator Specifications

Attachments Offering Guide *(continued)*

Not all attachments are available in all regions. Consult your Cat dealer for configurations available in your region.

Match No Match Working range front only

CAT PIN GRABBER COUPLER ATTACHMENTS

Undercarriage		Rear Outrigger/ Front Blade	Rear Blade/ Front Outrigger	Rear Outrigger/ Front Outrigger	Rear Blade
Counterweight		3300 kg (7,280 lb)	3300 kg (7,280 lb)	3300 kg (7,280 lb)	3300 kg (7,280 lb)
Boom Type		Variable Adjustable Boom	Variable Adjustable Boom	Variable Adjustable Boom	Variable Adjustable Boom
Stick Length		2200 mm (7'3")	2500 mm (8'2")	2200 mm (7'3")	2500 mm (8'2")
Hydraulic Hammers	H110 S	✓	✓	✓	✓
	H115 GC S	✓	✓	✓	✓*
	H115 S	✓	✓	✓	✓
Demolition and Sorting Grapples	G313 GC	✓	✓	✓	✓
	G314	✓	✓	✓	✓
Mobile Scrap and Demolition Shears	S3015 Flat Top	✓	✓	✓	✓
Compactors (Vibratory Plate)	CVP75	✓	✓	✓	✓

CW-30S DEDICATED COUPLER ATTACHMENTS

Undercarriage		Rear Outrigger/ Front Blade	Rear Blade/ Front Outrigger	Rear Outrigger/ Front Outrigger	Rear Blade
Counterweight		3300 kg (7,280 lb)	3300 kg (7,280 lb)	3300 kg (7,280 lb)	3300 kg (7,280 lb)
Boom Type		Variable Adjustable Boom	Variable Adjustable Boom	Variable Adjustable Boom	Variable Adjustable Boom
Stick Length		2200 mm (7'3")	2500 mm (8'2")	2200 mm (7'3")	2500 mm (8'2")
Hydraulic Hammers	H110 S	✓	✓	✓	✓
	H115 GC S	✓	✓	✓	✓*
	H115 S	✓	✓	✓	✓
Demolition and Sorting Grapples	G313 GC	✓	✓	✓	✓*
	G314	✓	✓	✓	✓*
Mobile Scrap and Demolition Shears	S3015 Flat Top	✓	✓	✓	✓*
Compactors (Vibratory Plate)	CVP75	✓	✓	✓	✓

(continued on next page)

M316 Wheeled Excavator Specifications

Attachments Offering Guide *(continued)*

Not all attachments are available in all regions. Consult your Cat dealer for configurations available in your region.

Match No Match Working range front only

CW-30 DEDICATED COUPLER ATTACHMENTS

Undercarriage		Rear Outrigger/ Front Blade		Rear Blade/ Front Outrigger		Rear Outrigger/ Front Outrigger		Rear Blade	
		3300 kg (7,280 lb)		3300 kg (7,280 lb)		3300 kg (7,280 lb)		3300 kg (7,280 lb)	
Boom Type		Variable Adjustable Boom		Variable Adjustable Boom		Variable Adjustable Boom		Variable Adjustable Boom	
		2200 mm (7'3")	2500 mm (8'2")	2200 mm (7'3")	2500 mm (8'2")	2200 mm (7'3")	2500 mm (8'2")	2200 mm (7'3")	2500 mm (8'2")
Hydraulic Hammers	H110 S	✓	✓	✓	✓	✓	✓	✓	✓
	H115 GC S	✓	✓	✓	✓	✓	✓	✓	✓*
	H115 S	✓	✓	✓	✓	✓	✓	✓	✓
Demolition and Sorting Grapples	G313 GC	✓	✓	✓	✓	✓	✓	✓*	
	G313 GC-Fixed CAN	✓	✓	✓	✓	✓	✓	✓	✓*
	G314	✓	✓	✓	✓	✓	✓	✓*	
	G317 GC	✓	✓	✓	✓	✓	✓		
Mobile Scrap and Demolition Shears	S3015 Flat Top	✓	✓	✓	✓	✓	✓	✓*	
Compactors (Vibratory Plate)	CVP75	✓	✓	✓	✓	✓	✓	✓	✓

S60 DEDICATED COUPLER ATTACHMENTS

Undercarriage		Rear Outrigger/ Front Blade		Rear Blade/ Front Outrigger		Rear Outrigger/ Front Outrigger		Rear Blade	
		3300 kg (7,280 lb)		3300 kg (7,280 lb)		3300 kg (7,280 lb)		3300 kg (7,280 lb)	
Boom Type		Variable Adjustable Boom		Variable Adjustable Boom		Variable Adjustable Boom		Variable Adjustable Boom	
		2200 mm (7'3")	2500 mm (8'2")	2200 mm (7'3")	2500 mm (8'2")	2200 mm (7'3")	2500 mm (8'2")	2200 mm (7'3")	2500 mm (8'2")
Hydraulic Hammers	H110 S	✓	✓	✓	✓	✓	✓	✓	✓
	H115 GC S	✓	✓	✓	✓	✓	✓	✓	✓
	H115 S	✓	✓	✓	✓	✓	✓	✓	✓
Demolition and Sorting Grapples	G313 GC	✓	✓	✓	✓	✓	✓	✓*	✓*
	G314	✓	✓	✓	✓	✓	✓	✓*	
	G317 GC		✓		✓		✓		
Mobile Scrap and Demolition Shears	S3015 Flat Top	✓	✓	✓	✓	✓	✓	✓*	
Compactors (Vibratory Plate)	CVP75	✓	✓	✓	✓	✓	✓	✓	✓

(continued on next page)

M316 Wheeled Excavator Specifications

Attachments Offering Guide (continued)

Not all attachments are available in all regions. Consult your Cat dealer for configurations available in your region.

Match No Match Working range front only

Some attachments require more hydraulic flow and are best suited with a machine that has HP2 circuits and a tiltrotator with a high flow swivel. Check the hydraulic capability of your machine and tiltrotator and the requirements of your attachment to ensure a proper match.

TRS14-CW-30S ATTACHMENTS

Undercarriage		Rear Outrigger/ Front Blade		Rear Blade/ Front Outrigger		Rear Outrigger/ Front Outrigger		Rear Blade
Counterweight		3300 kg (7,280 lb)		3300 kg (7,280 lb)		3300 kg (7,280 lb)		3300 kg (7,280 lb)
Boom Type		Variable Adjustable Boom		Variable Adjustable Boom		Variable Adjustable Boom		Variable Adjustable Boom
Stick Length		2200 mm (7'3")	2500 mm (8'2")	2200 mm (7'3")	2500 mm (8'2")	2200 mm (7'3")	2500 mm (8'2")	2200 mm (7'3")
Hydraulic Hammers	H110 GC S		✓		✓		✓	
	H110 S	✓	✓	✓	✓	✓	✓	
	H115 S		✓		✓		✓	
Demolition and Sorting Grapples	G212 GC	✓	✓	✓	✓	✓	✓	
	G212 GC-fixed CAN	✓	✓	✓	✓	✓	✓	
	G213 GC	✓	✓	✓	✓	✓	✓	
	G213 GC-fixed CAN	✓	✓	✓	✓	✓	✓	
Compactors (Vibratory Plate)	CVP75	✓	✓	✓	✓	✓	✓	✓*

NOTE: Use hammers on tiltrotators less than 10% of working hours per year or maximum 200 hours per year. Refer to your Operation and Maintenance Manual for recommended hydraulic flow requirements.

Some attachments require more hydraulic flow and are best suited with a machine that has HP2 circuits and a tiltrotator with a high flow swivel. Check the hydraulic capability of your machine and tiltrotator and the requirements of your attachment to ensure a proper match.

TRS14-CW-30 ATTACHMENTS

Undercarriage		Rear Outrigger/ Front Blade		Rear Blade/ Front Outrigger		Rear Outrigger/ Front Outrigger	
Counterweight		3300 kg (7,280 lb)		3300 kg (7,280 lb)		3300 kg (7,280 lb)	
Boom Type		Variable Adjustable Boom		Variable Adjustable Boom		Variable Adjustable Boom	
Stick Length		2200 mm (7'3")	2500 mm (8'2")	2200 mm (7'3")	2500 mm (8'2")	2200 mm (7'3")	2500 mm (8'2")
Hydraulic Hammers	H110 GC S	✓	✓	✓	✓	✓	✓
	H110 S	✓	✓	✓	✓	✓	✓
	H115 S		✓		✓		✓
Demolition and Sorting Grapples	G212 GC	✓	✓	✓	✓	✓	✓
	G212 GC-fixed CAN	✓	✓	✓	✓	✓	✓
	G213 GC	✓	✓	✓	✓	✓	✓
	G213 GC-fixed CAN	✓	✓	✓	✓	✓	✓
Compactors (Vibratory Plate)	CVP75	✓	✓	✓	✓	✓	✓

NOTE: Use hammers on tiltrotators less than 10% of working hours per year or maximum 200 hours per year. Refer to your Operation and Maintenance Manual for recommended hydraulic flow requirements.

(continued on next page)

M316 Wheeled Excavator Specifications

Attachments Offering Guide (continued)

Not all attachments are available in all regions. Consult your Cat dealer for configurations available in your region.

Match

No Match

Working range front only

Some attachments require more hydraulic flow and are best suited with a machine that has HP2 circuits and a tiltrotator with a high flow swivel. Check the hydraulic capability of your machine and tiltrotator and the requirements of your attachment to ensure a proper match.

TRS14-S60 ATTACHMENTS

Undercarriage		Rear Outrigger/ Front Blade		Rear Blade/ Front Outrigger		Rear Outrigger/ Front Outrigger		Rear Blade	
		3300 kg (7,280 lb)		3300 kg (7,280 lb)		3300 kg (7,280 lb)		3300 kg (7,280 lb)	
Boom Type		Variable Adjustable Boom		Variable Adjustable Boom		Variable Adjustable Boom		Variable Adjustable Boom	
		2200 mm (7'3")	2500 mm (8'2")	2200 mm (7'3")	2500 mm (8'2")	2200 mm (7'3")	2500 mm (8'2")	2200 mm (7'3")	2500 mm (8'2")
Hydraulic Hammers	H110 GC S	✓	✓	✓	✓	✓	✓	✓*	
	H110 S	✓	✓	✓	✓	✓	✓	✓	✓*
	H115 S	✓	✓	✓	✓	✓	✓	✓*	
Demolition and Sorting Grapples	G212 GC	✓	✓	✓	✓	✓	✓	✓*	
	G213 GC	✓	✓	✓	✓	✓	✓		
Compactors (Vibratory Plate)	CVP75	✓	✓	✓	✓	✓	✓	✓	✓

NOTE: Use hammers on tiltrotators less than 10% of working hours per year or maximum 200 hours per year. Refer to your Operation and Maintenance Manual for recommended hydraulic flow requirements.

M316 Wheeled Excavator Specifications

Standard and Optional Equipment

Standard and optional equipment may vary. Consult your Cat dealer for details.

	Standard	Optional		Standard	Optional
BOOM, STICKS AND LINKAGES			ENGINE		
5205 mm (17'1") Variable Adjustable boom	✓		Cat C4.4 Single Turbo diesel engine – meets Tier 4 Final/Stage V emission standards	✓	
2200 mm (7'3") stick		✓	Power mode selector	✓	
2500 mm (8'2") stick		✓	One-touch low idle with automatic engine speed control	✓	
Bucket linkage, 316-family without lifting eye		✓	Automatic engine idle shutdown	✓	
Bucket linkage, 316-family with lifting eye		✓	Work up to 3000 m (9,842 ft) above sea level without engine power de-rating	✓	
CAT TECHNOLOGY			52° C (125° F) high-ambient cooling capacity	✓	
Cat Product Link™	✓		Cold starting capability for –18° C (0° F)	✓	
Remote Flash capability	✓		Double element air filter with integrated precleaner	✓	
Remote Troubleshoot capability	✓		Electric fuel priming pump	✓	
Compatibility with radios and base stations from Trimble		✓			(continued on next page)
Capability to install 3D grade systems from Trimble		✓			
Cat Grade with 2D		✓			
Cat Grade with Advanced 2D		✓			
Cat Grade with 3D		✓			
Cat Payload		✓			
2D E-Fence		✓			
ELECTRICAL SYSTEM					
LED lights on boom and cab	✓				
LED lights on chassis (left-hand, right-hand) and counterweight		✓			
Programmable time-delay LED working lights	✓				
Roading and indicator lights, front and rear	✓				
Maintenance free batteries	✓				
Centralized electrical disconnect switch	✓				
Electrical refueling pump		✓			

M316 Standard and Optional Equipment

Standard and Optional Equipment (continued)

Standard and optional equipment may vary. Consult your Cat dealer for details.

	Standard	Optional		Standard	Optional
HYDRAULIC SYSTEM			SERVICE AND MAINTENANCE		
Boom, stick and bucket drift reduction valves	✓		Scheduled Oil Sampling (S·O·S SM) ports	✓	
Boom and stick lowering check valves	✓		Automatic lubrication system for implement and swing system		✓
Electronic main control valve	✓		UNDERCARRIAGE AND STRUCTURES		
Automatic hydraulic oil warm up	✓		All wheel drive	✓	
Element type main hydraulic filter	✓		Automatic brake/axle lock	✓	
One-slider joysticks	✓		Creeper speed	✓	
Two-slider joysticks		✓	Electronic swing and travel lock	✓	
Advanced Tool Control (one/two way high-pressure flow with drift reduction)	✓		Heavy-duty axles, advanced disc brake system and travel motor, adjustable braking force	✓	
Second high pressure auxiliary circuit (one/two way high-pressure flow)		✓	Oscillating front axle, lockable, with remote greasing point	✓	
Medium pressure auxiliary circuit (one/two way medium-pressure flow)		✓	10.00-20 16 PR, dual tires		✓
Heavy lift mode	✓		11.00-20 dual tires		✓
Quick coupler circuit for Cat pin grabber and CW dedicated	✓		315/70R22.5, no gap dual tires		✓
SmartBoom™		✓	445/70R 19.5, single tires		✓
Ride control		✓	Steps with tool box in undercarriage (left and right)	✓	
Cat tiltrotator support		✓	Two-piece drive shaft	✓	
Joystick steering		✓	Two speed hydrostatic transmission	✓	
Separate dedicated swing pump	✓		Undercarriage steps, for parallel blade		✓
Automatic swing brake	✓		Rear blade (radial) undercarriage		✓
Cat BIO HYDO™ Advanced biodegradable hydraulic oil		✓	Rear blade (radial)/front outrigger undercarriage		✓
Adjustable hydraulic aggressiveness	✓		Rear outrigger/front blade (radial) undercarriage		✓
Pattern changer	✓		Rear outrigger/front outrigger undercarriage		✓
SAFETY AND SECURITY			Fenders, front and rear, synthetic		✓
Rear and right-side-view cameras	✓		Travel restraint bracket for grapple/clamshell		✓
360° visibility		✓	3300 kg (7,280 lb) counterweight	✓	
Wide angle mirrors	✓				
Heated and remotely adjustable mirrors		✓			
Travel alarm		✓			
Signal/warning horn	✓				
Rotating beacon on cab and chassis		✓			
Neutral lever (lock out) for all controls	✓				
Ground-level accessible secondary engine shutoff switch in cab	✓				
Bluetooth® receiver	✓				
Anti-skid plate and countersunk bolts on service platform	✓				

Dealer Installed Kits and Attachments

Attachments may vary. Consult your Cat dealer for details.

CAB

- 75 mm (3") retractable seat belt

SAFETY AND SECURITY

- Bluetooth key fob

GUARDS

- Falling object guard system (not compatible with cab light cover, rain protector)
- Mesh guard full front (not compatible with cab light cover, rain protector)

M316 Cab Options

Cab Options

	Deluxe	Premium
Sound-suppressed ROPS cab	●	●
Heated seat with air-adjustable suspension	●	X
Heated and cooled seat with automatic adjustable suspension	X	●
Height-adjustable console, infinite with no tool	●	●
High-resolution 254 mm (10") LCD touchscreen monitor	●	●
Mechanical mirror	●	X
Electrical and adjustable heated mirror	X	●
Automatic bi-level air conditioner	●	●
Jog dial and shortcut keys for monitor control	●	●
Keyless push-to-start engine control	●	●
Auxiliary relay	○	○
51 mm (2") orange seat belt	●	●
Unfastened seat belt warning	●	●
Bluetooth integrated radio (including USB, aux port and microphone)	●	●
2 × 12V DC outlets	●	●
Document storage	●	●
Cup and bottle holders	●	●
Openable two-piece front window (laminated)	●	○
Fixed one-piece front window (P5A classified)	X	○
Parallel wiper with washer	●	●
Fixed glass skylight	●	●
LED dome lights	●	●
Foot illumination	●	●
Roller rear sunscreen	X	●
Rear window emergency exit	●	●
Washable floor mat	●	●
Beacon ready	●	●
FOGS "ready"	●	●
Vandal guards "ready"	●	●
Two LED cab lights	●	●
Rain visor	●	●

- Standard
- Optional
- X Not available

The following information applies to the machine at the time of final manufacture as configured for sale in the regions covered in this document. The content of this declaration is valid as of the date issued; however, content related to machine features and specifications are subject to change without notice. For additional information, please see the machine's Operation and Maintenance Manual.

For more information on sustainability in action and our progress, please visit <https://www.caterpillar.com/en/company/sustainability>.

Engine

- The Cat® C4.4 engine meets U.S. EPA Tier 4 Final and EU Stage V emission standards.
- Cat diesel engines are required to use ULSD (ultra-low sulfur diesel fuel with 15 ppm of sulfur or less) or ULSD blended with the following lower-carbon intensity fuels up to:
 - ✓ 20% biodiesel FAME (fatty acid methyl ester)*
 - ✓ 100% renewable diesel, HVO (hydrotreated vegetable oil) and GTL (gas-to-liquid) fuels

Refer to guidelines for successful application. Please consult your Cat dealer or "Caterpillar Machine Fluids Recommendations" (SEBU6250) for details.

**Engines with no aftertreatment devices can use higher blends, up to 100% biodiesel (for use of blends higher than 20% biodiesel, consult your Cat dealer).*

Air Conditioning System

- The air conditioning system on this machine contains the fluorinated greenhouse gas refrigerant R134a (Global Warming Potential = 1430). The system contains 0.8 kg (1.8 lb) of refrigerant which has a CO₂ equivalent of 1.216 metric tonnes (1.340 tons).

Paint

- Based on best available knowledge, the maximum allowable concentration, measured in parts per million (PPM), of the following heavy metals in paint are:
 - Barium < 0.01%
 - Cadmium < 0.01%
 - Chromium < 0.01%
 - Lead < 0.01%

Sound Performance

Operator Sound 2000/14/EC – 70 dB(A)

Spectator Sound 2000/14/EC – 102 dB(A)

- Operator Sound – The operator sound level is measured according to the procedures specified in 2000/14/EC, for a cab offered by Caterpillar, when properly installed and maintained and tested with the door and windows closed.
- Exterior Sound – The labeled spectator sound power level is measured according to the test procedures and conditions specified in 2000/14/EC.
- Hearing protection may be needed when operating with an open operator station and cab (when not properly maintained or doors/windows open) for extended periods or in noisy environment(s).

Oils and Fluids

- Caterpillar factory fills with ethylene glycol coolants. Cat Diesel Engine Antifreeze/Coolant (DEAC) and Cat Extended Life Coolant (ELC) can be recycled. Consult your Cat dealer for more information.
- Cat Bio HYDO Advanced is an EU Ecolabel approved biodegradable hydraulic oil.
- Additional fluids are likely to be present, please consult the Operations and Maintenance Manual or the Application and Installation guide for complete fluid recommendations and maintenance intervals.

Features and Technology

- The following features and technology may contribute to fuel savings and/or carbon reduction. Features may vary. Consult your Cat dealer for details.
 - Advanced hydraulic systems balance power and efficiency
 - Up to 14% more swing torque maximizes performance to get the job done faster
 - New hydraulic oil filter provides longer life with a 3,000-hour replacement interval
 - Eco mode minimizes fuel consumption for light applications
 - One-touch low idle with automatic engine speed control
 - Boost productivity and increase operating efficiency with optional Cat technologies
 - Remote flash and remote troubleshoot

Recycling

- The materials included in machines are categorized as below with approximate weight percentage. Because of variations of product configurations, the following values in the table may vary.

Material Type	Weight Percentage
Steel	59.23%
Iron	10.38%
Nonferrous Metal	2.31%
Mixed Metal	9.46%
Mixed-Metal and Nonmetal	0.01%
Plastic	1.28%
Rubber	3.31%
Mixed Nonmetallic	0.00%
Fluid	7.19%
Other	4.41%
Uncategorized	2.76%
Total	100%

A machine with higher recyclability rate will ensure more efficient usage of valuable natural resources and enhance End-of-Life value of the product. According to ISO 16714 (Earthmoving machinery – Recyclability and recoverability – Terminology and calculation method), recyclability rate is defined as percentage by mass (mass fraction in percent) of the new machine potentially able to be recycled, reused, or both.

All parts in the bill of material are first evaluated by component type based on a list of components defined by the ISO 16714 and Japan CEMA (Construction Equipment Manufacturers Association) standards. Remaining parts are further evaluated for recyclability based on material type.

Because of variations of product configurations, the following value in the table may vary.

Recyclability – 89%

For more complete information on Cat products, dealer services, and industry solutions, visit us on the web at www.cat.com

© 2022 Caterpillar
All rights reserved

Materials and specifications are subject to change without notice. Featured machines in photos may include additional equipment. See your Cat dealer for available options.

CAT, CATERPILLAR, LET'S DO THE WORK, their respective logos, "Caterpillar Corporate Yellow," the "Power Edge" and Cat "Modern Hex" trade dress as well as corporate and product identity used herein, are trademarks of Caterpillar and may not be used without permission.

AEXQ3018-03 (11-2022)
Replaces AEXQ3018-02
Build Number: 07C
(Eur)

